



Instruction Manual

For Your
Haskris LX System

Installation
Start-up
Operation
Maintenance

Rev. 3.0 1-26-17

| | | |
|----------|--|-----------|
| 1 | PRELIMINARY INFORMATION..... | 1 |
| 1.1 | Technical Support..... | 1 |
| 1.2 | Operational Information | 1 |
| 1.3 | LX Generation | 1 |
| 2 | INSTALLATION..... | 2 |
| 2.1 | Unpacking System..... | 2 |
| 2.2 | Proper System Location..... | 2 |
| 2.2.1 | Water-Cooled Systems | 2 |
| 2.2.2 | Air-Cooled Systems | 2 |
| 2.3 | Electrical Power | 3 |
| 2.4 | Circulating Water Connections | 4 |
| 2.5 | Building Water Recommendations..... | 4 |
| 3 | SYSTEM STARTUP..... | 6 |
| 3.1 | Water Tank Filling..... | 6 |
| 3.2 | Water Pump Priming | 6 |
| 3.3 | Liquid Refrigerant Removal..... | 6 |
| 3.4 | 50-60 Hertz Selector Switch..... | 7 |
| 3.5 | Final Inspection | 7 |
| 4 | OPERATION..... | 8 |
| 4.1 | Adjusting the supply Water Temperature..... | 8 |
| 4.2 | Water Pressure Bypass | 9 |
| 4.3 | Refrigerant Pressure Control | 10 |
| 4.3.1 | Low Pressure Control | 10 |
| 4.3.2 | High Pressure Control | 10 |
| 4.3.3 | High Pressure Control Fan Cycling Switch | 11 |
| 4.4 | System Troubleshooting | 11 |
| 4.4.1 | Low Liquid Level Fault..... | 11 |
| 4.4.2 | Temperature Fault | 11 |
| 4.4.3 | Low Refrigerant Pressure Fault | 12 |
| 4.4.4 | High Refrigerant Pressure Fault | 13 |
| 5 | MAINTENANCE | 14 |
| 5.1 | Water Storage Tank | 14 |
| 5.1.1 | Tank Inspection | 14 |
| 5.1.2 | Frequency of Water Changes | 14 |
| 5.1.3 | Biological Growth | 14 |
| 5.2 | Air-Cooled Condenser..... | 14 |
| 5.3 | Filters | 15 |
| 5.3.1 | Nylon Suction Strainer..... | 15 |
| 5.3.2 | Supply Line Filter Option..... | 15 |
| 5.4 | Pump Replacement..... | 16 |
| 5.5 | Drain line | 16 |
| 6 | WARRANTY | 17 |
| 6.1 | Standard Product Warranty..... | 17 |

1 PRELIMINARY INFORMATION

1.1 Technical Support

If at any time you have questions, encounter problems or need spare parts for your Haskris system, please contact us by any of the following means:

Phone: 001-847-956-6420
Fax: 001-847-956-6595
Email: service@haskris.com
Website: www.haskris.com

Our website contains information addressing frequently-asked questions, trouble-shooting guides, and technical documentation.



NOTE!

When contacting Haskris, have the *Serial Number* (located on the rear side of your Haskris system) available when you call. The serial number enables us to address problems quickly and effectively.

1.2 Operational Information

This appliance is not intended for use by persons (including children) with reduced physical, sensory or mental capabilities, or lack of experience and knowledge, unless they have been given supervision or instruction concerning use of the appliance by a person responsible for their safety.

Children should be supervised to ensure that they do not play with the appliance.

1.3 LX Generation

The LX has had 2 generations that are referenced in this manual. These can be quickly identified by the following:

Generation1:

- (1) Controller on front Panel
- (4) Alarm LEDs on front Panel
- Front of unit is rounded

Generation2:

- (1) Controller on front Panel
- (0) Alarm LEDs on front Panel
- Front of unit has corners

Identify the Haskris LX Generation and use that as a reference through the manual.

2 INSTALLATION

2.1 Unpacking System

Upon delivery, visually inspect your Haskris LX system for any obvious damage. If damage is found, and there is reason to believe the system was mishandled, note the damage in detail on the delivery receipt. We recommend taking photographs if possible. Contact the delivering carrier immediately to file a claim. All shipping containers and packaging materials should be retained to help substantiate the claim. We also ask that you call Haskris if the system has been damaged in shipment. We will assist in rectifying the situation.

Your Haskris LX system has been packaged in a method allowing for simple unpacking. The following steps will guide you through unpacking the system.

1) Remove the packing bands and the outer corrugated sleeve.

2a) If Foam packaging is used:

- a. Remove the foam blocking from the top.
- b. Gently tilt the unit left to remove the right half blocking from underneath, then gently right to remove the left blocking.

2b) If Mounting Bolts are used:

- a. Remove 4 lag bolts from wood blocks.

3) Carefully pick up the unit and set it gently down beside the pallet. Do not roll off edge of pallet as the sudden drop may damage the unit.

2.2 Proper System Location

This Haskris LX system is designed for use in a clean, indoor environment.

Position the system for clear access to the front panel, where all controls, indicators and readouts are located. Access to the top and side panels is required to perform maintenance and repair procedures.

2.2.1 Water-Cooled Systems

For systems with water-cooled condensers:

These systems are designed to circulate clean, temperature-controlled water through your equipment, while making use of an existing source of *building water* as a means of dissipating heat. As a result, no heat will be introduced into the room. (Building water may be any source of cold water, including city/tap water or in-house chilled water.)

2.2.2 Air-Cooled Systems

For systems with air-cooled condensers:

Acceptable ambient air temperatures are +55° F to +90° F (+13° C to +32° C).

Avoid dusty areas, and periodically check to make sure that the condenser is clean (refer to Section 5.2 for cleaning instructions).

Minimum Clearance Requirements

Provide sufficient clearance, to allow free movement of air across the condenser. A lack of cool/fresh air to the condenser will result in reduced cooling capacity, and possibly the complete shutdown of the unit. Figure 2-1 and Figure 2-2 present the minimum clearance requirements for the air cooled units.

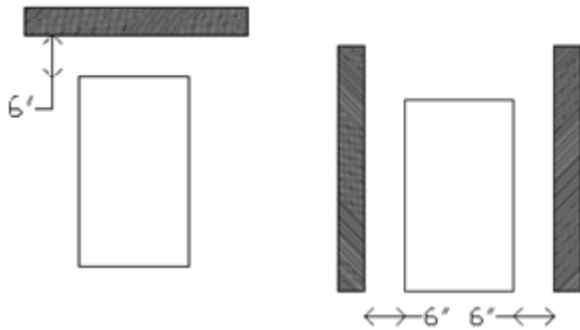

Figure 2-1

Figure 2-2

A minimum of 6" (15cm) of clearance from the back of the unit to any obstructions must be maintained to provide adequate air flow through the condenser.

A minimum of 6" (15cm) of clearance must be maintained from the sides of the unit if large obstructions are present on both sides of the unit. The front and rear of the unit should be completely open.

Under Counter Operation

Operation under a counter or similar overhead obstruction is possible when the minimum clearance from the front, sides and rear of the unit are maintained, and when the counter or similar obstruction is a minimum of 2" (5cm) from the top of the unit.

Service loops should be installed in the process water lines, condenser water lines (water cooled systems only), and power cord to allow the unit to be easily pulled out for service.

Contact Haskris at (847) 956-6420 for additional information on system operation and minimum clearance requirements for restrictive environments.

2.3 Electrical Power

A copy of the nameplate can be found on the back of your Haskris LX system.

The wiring diagram for your Haskris LX system can be found on the underside of the top panel of the unit.



We recommend contacting a licensed electrician to perform the electrical installation. These professionals are familiar with local electrical codes and will be aware of specific requirements that apply to your area.

We recommend a service disconnect switch and time delay fusing be installed, per the wiring diagram found inside your Haskris LX system. Your system will use single-phase power with a power cord.

Plug the system in as you would any electrical appliance, making sure to follow the Proper System Location guidelines as outlined in Section 2.2.

If the supply cord is damaged, it must be replaced by the manufacturer, its service agent or similarly qualified persons in order to avoid a hazard.



Crankcase Heater – Leave disconnect ON (energized) overnight prior to system start up. This energizes the crankcase heater and drives out any accumulated liquid refrigerant in the compressor. See Section 3.3 for details.

2.4 Circulating Water Connections

Supply and Return Lines

Supply and return connections have been provided on the rear of the unit.

All interconnecting hose and piping should be run at the same size as the connections to minimize external pressure drop. We suggest the use of high-pressure hose for the entire installation, or the use of copper piping for long runs. Do NOT use steel pipe. If copper piping is used, a short segment of hose should be used at each connection point to absorb vibration. Copper piping/tubing (and hose in some instances) should be insulated to prevent condensation.

Haskris recommends that an opaque, 150 psi (1.03 MPa) minimum rated, reinforced EPDM hose be used between the Haskris system and the equipment being cooled, so that no light is introduced, thus minimizing biological growth. Contact Haskris if the system operating pressure is above 100 psi (0.7 MPa).

If your Haskris chiller is supplied with a new detachable hose-set, these new hose-sets are to be used while the old hose-sets should not be reused.

2.5 Building Water Recommendations

To ensure the reliable operation of water-cooled systems:

- Provide a minimum inlet pressure/differential pressure of 25 psi (0.17 MPa) and maximum differential pressure of 50 psi (0.35 MPa) between the building water inlet and outlet, measured at the chiller connections.

- Maximum inlet pressure is 100 psi (0.7 MPa), unless otherwise specified. Be sure to check back pressure on the outlet side. A high inlet pressure alone will not ensure adequate flow.
- Connect the inlet and outlet to the condenser per the labels on each port. See Figure 2-3.



Figure 2-3

- Required differential pressure will vary among installations, depending on the temperature of the source water.
- Install a hand valve in an accessible location in the building water inlet and outlet lines. A plumbing “Y” strainer, with an 80 mesh screen at the inlet, is recommended instead of a filter, and is required to limit debris from entering the water regulating valve and the water-cooled condenser.
- In-line filters are not recommended. They clog easily and restrict water flow, reducing chiller cooling capacity. This leads to compressor cycling on the refrigerant pressure control requiring a manual reset of the refrigerant pressure control.

Table 2-1. Condenser Water Quality Information

| Component | Allowable Quantity |
|---------------------------|--------------------|
| Iron | <3 ppm |
| Manganese | <3 ppm |
| Aluminum | <0.1 ppm |
| Free Carbon Dioxide | 5 ppm |
| Ammonia | 2 mg/L |
| pH | >8 |
| Dissolved Oxygen | <3 ppm |
| Sulfate to Chloride Ratio | <3:1 |

Figure 2-4. Building Water Temperature vs. GPM per (1) Horsepower of Cooling

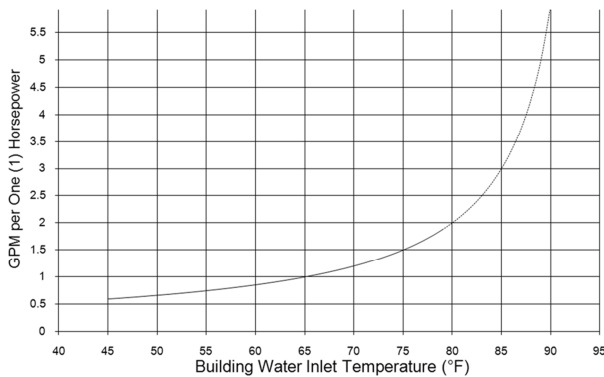

Table 2-2. Unit Capacity in Horsepower

| Unit | Horsepower |
|------|------------|
| LX1 | 0.5 |
| LX2 | 1.25 |
| LX3 | 2 |

Automatic Water Regulating Valve

Your Haskris unit will control building water flow through the water-cooled condenser by means of a modulating, pressure-actuated water regulating valve (see Figure 2-5).



Figure 2-5. Automatic Water Regulating Valve

Function

This valve maintains factory set operating refrigerant pressure in the condenser. It also modulates building water flow to a minimum usage when the refrigeration system is running, and it automatically shuts off the building water when the compressor shuts OFF.

CAUTION! The water regulating valve can easily be damaged by water flowing in the reverse direction (see arrow on casting) or rough treatment of the capillary tube which senses refrigerant pressure. The valve should not require field adjustment; it has been adjusted and tested prior to shipment.

The automatic water regulating valve modulates closed when the compressor stops running, or the unit is off, conserving water.

Hot Gas Bypass

Haskris LX systems are equipped with hot gas bypass and have a continuously running compressor, requiring a constant flow of building water through the water-cooled condenser when the unit is on.

3 SYSTEM STARTUP

3.1 Water Tank Filling

- 1) Fill the tank with clean, potable (drinkable) distilled water.
- 2) Stop filling when the water level is just below the threaded fill neck near the top of the tank.

3.2 Water Pump Priming

In most cases the system should prime automatically. However, if you have a turbine pump and you should experience difficulty with pump priming, complete the following steps:

- 1) Turn the chiller off and disconnect its power cord from the wall.
- 2) With the water tank filled as described in section 3-1, locate the air vent plug on the head of the pump, as shown circled in Figure 3-1. The air vent screw opening is shown in Figure 3-2.

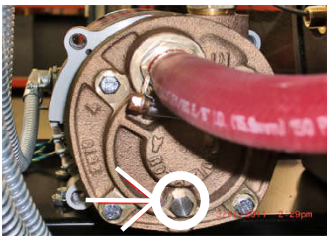

Figure 3-1. Priming Air Vent Screw

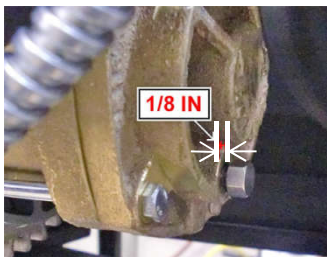

Figure 3-2. Air Vent Screw Opening

- 3) Use a wrench to loosen (counter-clockwise) the vent plug enough to allow water to exit through the threads without vent plug removal.

- 4) During the priming process, a small amount of water will drip from the screw hole. This purges the air from within the pump head. To avoid spillage, place a small paper towel under the pump head (Figure 3-3).

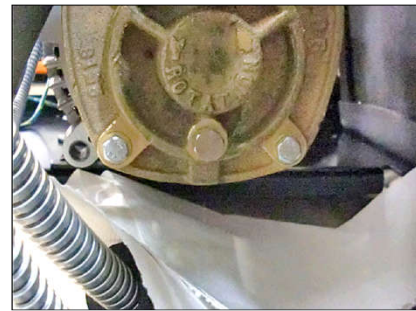

Figure 3-3. Paper Towel Placement

- 5) Plug the chiller power cord into the wall and turn the chiller on.
- 6) When the pump runs, verify that there is proper flow through the system piping.
- 7) Add water to the tank as necessary to maintain the level above the float switch and below the threaded fill neck.
- 8) Check for leaks.
- 9) Continue with the remainder of the startup procedures.

3.3 Liquid Refrigerant Removal

Liquid refrigerant may accumulate inside the compressor during shipping, especially when exposed to cold ambient temperatures. During start-up, it is important to remove liquid refrigerant from the compressor to prevent damage to the compressor. This can be accomplished by using the ON-OFF switch.

- 1) Turn the system power ON until the compressor starts.
- 2) Turn the system OFF and ON 3 or 4 times before switching the system ON permanently.

Crankcase Heater

To keep liquid refrigerant out of the compressor when the system is shut down for an extended period of time (overnight and during the weekend) a crankcase heater has been included that will evaporate any liquid refrigerant in the compressor. As long as main power is supplied to the Haskris LX system, the crankcase heater will be energized, even if the ON-OFF switch is in the OFF position.

3.4 50-60 Hertz Selector Switch (if applicable)

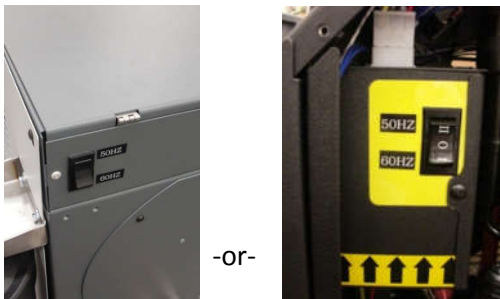

Figure 3-3. 50-60 Hertz Compressor Selector Switch

The selector switch is included with 50-60 Hertz dual-rated units. The unit **will not provide cooling** until a selection is made. The frequency selection energizes the compressor. The selector switch is located in either the back of the unit or behind the right side panel. To select the 50 Hertz option, flip the switch to the upward position. To select the 60 Hertz option, flip the switch to the downward position. Fasten the right side panel back on to the unit after your selection has been made.

3.5 Final Inspection

Water Tank Level

Once the system is ON, the water pump will fill the closed loop with water and remove all the air in the process. As the interconnecting hose and pipe fill with water, the level in the water tank will drop. You should have an extra supply of water on hand to replenish the water tank level as necessary.

If the water level in the tank drops below the float switch, the unit will shut down. To prevent the premature shut down of the unit during initial startup it is recommended that you add water to maintain a consistent level in the tank while the air is displaced from the closed loop.

Leaks and Line Debris

Check to make sure all external piping is leak-tight and that the system is operating satisfactorily. During initial operation the circulating water will flush debris from the closed loop and deposit it into the water tank. If necessary, drain the tank and refill it with clean water. A convenient gravity drain has been provided on the underside of the tank for this purpose.

Inspection for Algae

Check the system after one week of operation. If algae start to form the system will need to be cleaned and disinfected before refilling with clean, potable (drinkable) distilled water. Please keep in mind that you need the instrument manufacturer's approval before using any water additive formulated to minimize biological growth in the cooling water. Consult Section 5 of this manual (or the Haskris website) for maintenance recommendations, flushing instructions and/or recommendations on approved additives for use in Haskris LX systems.

4 OPERATION

4.1 Adjusting the supply Water Temperature

Press the UP or DOWN arrow button to adjust the temperature set-point. See Figure 4-1 for a description of the LX system controller display. The set point will be shown directly above the process water supply on main screen.



Figure 4-1. LX Controller Display – Gen 2

For 1st generation units, the set-point (SV) will be shown on the lower display. The process (measured) water temperature will be displayed on the upper display.

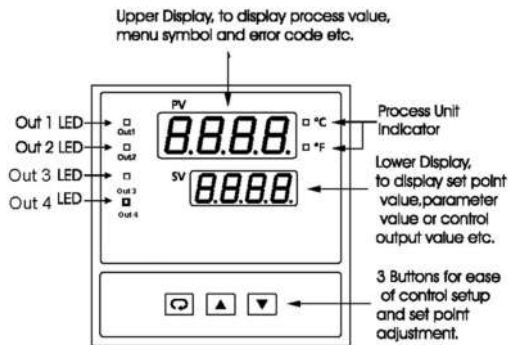

Figure 4-2. LX Controller Display – Gen 1

NOTES:

Temperature is Pre-Set: Haskris has pre-set the supply water temperature to 68° F (20° C). On initial start-up, apply the actual heat load and wait 15-30 minutes for the temperature to stabilize.

Allowable Adjustments: The following procedures are intended for supply water temperature adjustments only. All other control parameters are factory set for optimum performance and should not be adjusted. If it appears that “tuning” is required, please contact Haskris for further information.

Adjust While System is Running: Make all water temperature adjustments while the system is running under the actual heat load.

Permissible Temperature Settings: The permissible supply water temperature range is +58 to +70°F (+14 to +21°C.) If a temperature setting outside of this range is required, please contact Haskris and we will advise you of precautions and the proper procedures to follow.

Response Time for Adjustments: Allow up to 15 minutes for any temperature adjustments to take effect. This is due to the thermal mass of the system and the nature of the cooling system.

Condensation Reminder: Setting the supply water temperature below the room dew point will cause condensation to form on the surfaces of the equipment being cooled, with resultant damage. Insulate the cooling water lines if the supply water temperature is below the dew point in the room. Consult a dew point chart to calculate the dew point in your environment.

4.2 Water Pressure Bypass

Your system is provided with either an internal flow restrictor line (Qmin) or a bypass valve shown below. This valve modulates and does not snap open and closed.



Figure 4-3. Qmin and Bypass/Relief Valve

Flow Restrictor Line Functions

1) The function of the internal flow restrictor bypass is to divert a constant stream of water from the pump discharge. The water is diverted into the bypass line, through the evaporator and into the storage tank.

This feature allows the unit to run properly regardless of flow rate being supplied from the chiller supply line.

2) To adjust flow in an LX with a flow restrictor line, an external metering valve must be used. These metering lines are used on units with centrifugal pumps which have a self-limiting maximum pressure in the event of complete supply line restriction.

Bypass Valve Functions

1) The valve's primary function is to divert the water pump discharge flow whenever the pump pressure reaches the bypass pressure setting. The water is diverted into the bypass line, through the evaporator and into the storage tank.

This reaction occurs when the closed-loop becomes restricted, such as when a solenoid valve on your equipment closes, or some other flow restriction develops. The bypass would also open if the pressure relief setting was not set above the required pressure to overcome the resistance to flow (pressure drop) in the closed loop.

2) As a secondary function, the valve can be used for partial-flow diversion. If the flow characteristics of the pump cause excessive pressure drop through the heat exchanger on the equipment that is being cooled, this valve can be adjusted to bypass some of the excess water. This reduces the flow through the equipment, thereby reducing the pressure required to complete the circuit.

Flow Restrictor Adjustment Procedure

Units with a flow restrictor must be adjusted with an external metering valve. If less than maximum flow is required, slowly close the valve until the desired flow rate is achieved.

Relief Valve Adjustment Procedure

The valve has been preset for a maximum pressure of 60 psig (.42 MPa) in order to limit the pressure of the cooling water flowing to your equipment. An adjustment screw is located under the knurled brass cap or on top of the valve.

NOTE: To find the pressure setting of the bypass valve, restrict the flow of supply water from the Haskris LX system (completely pinch the hose or close the supply hand valve if supplied). The pressure gauge will then indicate the valve set-point.

1) Loosen the locking nut at the base of the adjustment stem.

2) Rotate the screw inward (clockwise) to increase the water pressure required to open the valve, or rotate the screw outward (counter-clockwise) to decrease the water pressure required to open the valve.

**NOTE!**

When rotating the screw outward to decrease the water pressure, make sure you do not completely remove the screw; this prevents the valve from leaking.

3) Tighten the locknut at the base of the adjustment stem.

As noted above, the valve does not snap open and closed. It will crack open at approximately 10-15 psi (0.07-0.1 MPa) below its set-point. The valve continues to open gradually, increasing the amount of bypass, as pressure approaches the valve set-point. When the set-point is reached, all of the flow from the pump is being bypassed. For this reason the valve should be set to a minimum of 15 psi (0.1 MPa) above the normal operating pressure to ensure full flow of the pump through the closed loop.

4.3 Refrigerant Pressure Control

The refrigerant pressure controls are safety devices. The refrigerant pressure controls shut the system down when refrigerant operating pressures are outside the safe limits set by Haskris.

4.3.1 Low Pressure Control

The low pressure control shuts the system down when a significant amount of refrigerant has leaked out of the system, or when a restriction has occurred in the refrigeration circuit.

The low pressure control also serves as an added level of freeze-protection.

The low pressure control is preset to 55 psig (0.38 MPa) with a tolerance of +/- 5 psig (0.035 MPa), and is not adjustable.

The low pressure control must be manually reset on generation 2 units after the refrigerant pressure decreases to a safe level. Cycle the ON-OFF switch to reset the alarms on these units.

Generation 1 units have the low pressure control automatically reset after the refrigerant pressure increases to 75psig (0.52MPa).

The low pressure control can be found in the compressor suction line of the Haskris LX system near the front of the unit and can be seen through the left side panel openings. See Figure 4-4.

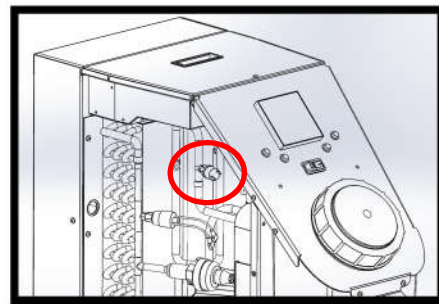

Figure 4-4. Low Pressure Switch

4.3.2 High Pressure Control

The high pressure control shuts the unit down when a high pressure condition is created by insufficient building water flow through a water-cooled condenser or insufficient airflow through an air-cooled condenser.

The high pressure control is preset to 385 psig (2.65 MPa) with a tolerance of +/- 20 psig (0.1 MPa), and is not adjustable.

The high pressure control must be manually reset after the refrigerant pressure decreases to a safe level.

Generation 2 units have the high pressure reset through the controller. Cycle the ON-OFF switch to reset the alarms.

Generation 1 units have the high pressure found on the compressor discharge line of the Haskris LX system, near the rear of the unit, and can be seen through the left side panel openings of these units

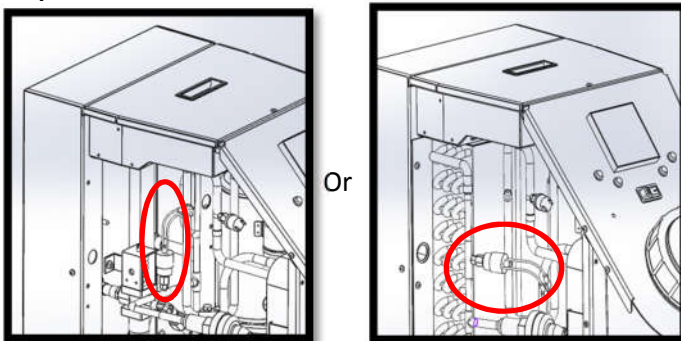

Figure 4-5. High Pressure Switch (Water and Air cooled configurations shown)

4.3.3 High Pressure Control Fan Cycling Switch

The head pressure control maintains head pressure above 195 psig (1.34 MPa) by cycling off the top fan in the system. The fan will turn back on when the head pressure has reached 300 psig (2.1 MPa)

The head pressure control switch can be found in the compressor discharge line of the Haskris LX system.

4.4 System Troubleshooting

If the system is short-cycling (turning on and off rapidly), or if the system will not come on at all when cooling is required, it is likely the system has been locked out by the one of the system safety controls. Refer to the sections below for further

troubleshooting advice, or contact Haskris Co. at 847-956-6420.

Your Haskris LX system is equipped with fault indicator lights on the controller or independently on the front panel to assist with troubleshooting the unit in the event of a fault.

During normal operation the indicator lights will be off. The fault indicator lights will illuminate when a fault condition associated with the light has occurred and shut the system down.

4.4.1 Low Liquid Level Fault

All Haskris LX systems are furnished with a liquid-level switch. When the water level drops below a safe level, the liquid level switch opens, shutting the system down and illuminating the low liquid level fault alarm.

To restart the system after a low liquid level fault:

- 1) Remove the tank fill cap and verify the water level in the tank is below the liquid level switch.
- 2) Check the system for leaks. Once the source of the water loss has been corrected proceed with step 3.
- 3) Refill the tank with clean, potable (drinkable) distilled water to just below the threaded fill neck on the tank. Cycle the ON-OFF switch to reset the alarm.

4.4.2 Temperature Fault

The LX system is designed to shut down if the process value (temperature) of the water becomes too high (above 78°F/ 26°C), or too low (below 55°F/13°C).

To restart the system after a temperature fault:

1) Read the process value from the controller to determine if the system shut down was due to high or low temperature conditions (the process value is the top line of the controller).

Low temperature conditions

- 1) Confirm the temperature set point does not interfere with the low temperature alarm set point.
- 2) If the temperature set point is above the low temperature alarm set point, contact Haskris for further troubleshooting instructions.

High Temperature Conditions

- 1) Adjust the set point for alarm 1 above the process water temperature to start the chiller. This is done by:
 - a) Gen 2: Pressing the menu button, scrolling to the set points page, going to the high temp SP line, pressing the up and down arrows to change, and pressing the enter key to set.
 - b) Gen 1: Pressing the looped arrow once on the controller and pressing the up and down arrows to change.
- 2) Confirm that the refrigerant compressor is operating. If this does not resolve the fault, contact Haskris for further troubleshooting instructions.

4.4.3 Low Refrigerant Pressure Fault

- 1) Confirm that the temperature set point is within the allowable range. See section 4.1.1 for the acceptable range of set point values.
 - 2a) For systems with air cooled condensers, confirm that the ambient air temperature is within range (see section 2.2.2)
 - 2b) For systems with water cooled condensers confirm the water pressure regulating valve is functioning correctly by checking the building water flow and comparing to Chart 1 in section 2.5
- 3) If the switch will not reset, or the unit continues to short cycle, the cause of the low pressure fault may be associated with a significant loss of charge. Contact Haskris at (847) 956-6420 if persistent low refrigerant pressure faults occur at your location, or you are unable to restart the system.

4.4.4 High Refrigerant Pressure Fault

High Pressure Fault (Systems with Air-Cooled Condensers)

To restart the system:

- 1) Confirm that ambient air temperature is within range (see section 2.2.2).
- 2) Check that the condenser fins are clean and allow ambient air flow through the condenser. See section 5.2 for instructions on cleaning the condenser fins.
- 3) Verify that the minimum clearance requirements around the unit have been met. See section 2.2.2.
- 4) Confirm that hot air is not being directed to the condenser inlet from another application.
- 5) Manually reset the refrigerant pressure control by either cycling the ON-OFF switch (Gen 2) or pressing the black reset button on top of the high pressure control switch (Gen 1) and check that water is being circulated by the pump (pressure gauge shows discharge pressure or other means). Refer to section 4.3.2 for the location of the high pressure switch.
- 6) The system should restart. If the system will not start or will not remain on, there may still be a fault condition. Please contact Haskris if you have difficulty resolving this fault condition.

High Pressure Fault (Systems with Water Cooled Condensers)

- 1) Investigate the source of insufficient building water flow.

| Possible Sources | Action |
|---|--|
| Dirty strainer on the building water (do not use a filter) | Clean strainer and/or Contact Facilities |
| Unplanned building water shutdown | Contact Facilities |
| Imbalanced condition in a building water loop (sudden change of differential pressure and/or temperature) | Contact Facilities |

- 2) After the insufficient flow issue is identified and resolved, either cycle the unit ON-OFF switch (Gen 2) or press the manual reset button (Gen 1) on top of the high refrigerant pressure switch. Refer to section 4.3.2 for the location of the high refrigerant pressure switch.
- 3) The system should restart. If the system will not start or will not remain on, there may still be a fault condition in the building water circuit. Please contact Haskris if you have difficulty resolving this fault condition.

5 MAINTENANCE

5.1 Water Storage Tank

5.1.1 Tank Inspection

Periodically inspect the tank to make sure that the water is clear and that there has been no accumulation of debris.

5.1.2 Frequency of Water Changes

The frequency of required water changes varies according to the condition of the water at your individual environment; however, Haskris recommends that the water in the tank be changed once or twice per year at a minimum.

5.1.3 Biological Growth

Haskris recommends using opaque hose, between the Haskris LX system and the equipment being cooled, to minimize light introduced into the system, thus minimizing biological growth.

If your system exhibits biological growth, we offer the following recommendations:



It is EXTREMELY important that you check with the manufacturer of the equipment being cooled to ensure that the use of any biologically inhibiting chemicals or additives is compatible with their equipment.

System Flushing

Flush the system by using one of the following 2 methods:

Method 1 - Original equipment manufacturer does NOT allow the use of chemicals in the system:

Run a short hose directly from the supply to the return line in a closed loop in order to flush the Haskris LX system out.

Method 2 - Original equipment manufacturer allows the use of hydrogen peroxide:

Add one 1.5 oz. (45 mL) of 3% hydrogen peroxide to LX1 and LX2 systems. For LX3 systems add 2.0 oz. (60 mL) of 3% hydrogen peroxide. Circulate the water for 20-30 minutes. Drain the system and refill with clean, potable (drinkable) distilled water.

Chemical Additives

Haskris recommends that additives are only used as a means of last resort. Various concentrations of a variety of chemicals can be used to minimize (or eliminate) biological growth on an ongoing basis. Please contact Haskris if you have any further questions.

Water Filtration

A 5-micron filter is very helpful in keeping the water recirculation system clean. Section 5.3 further describes this mechanism.

5.2 Air-Cooled Condenser

Haskris LX systems with air-cooled condensers draw a substantial amount of air across the condenser fins and coils. As dust and debris collect, heat transfer becomes less efficient, resulting in the loss of cooling capacity. To remove the accumulation of debris, vacuum the condenser fins thoroughly on a regular basis. A brush may be used to loosen compacted debris.

5.3 Filters

5.3.1 Nylon Suction Strainer



Cavitation due to improper strainer maintenance will damage the pump and is not covered under warranty.

The strainer is located inside the water storage tank of your system and prevents debris from damaging the pump impeller.

Ordering Replacement Strainers

Replacement strainers may be purchased from Haskris. Order Haskris part number 4706 when ordering a single replacement strainer. Contact Haskris to confirm the strainer part number if you are unsure.

When to Clean the Strainer

After initial start-up, check the strainer on a monthly basis. The mesh should be clean. If the mesh feels slippery or “slimy”, this is an indication of biological growth. If water cannot pass through the end of the strainer, the pump will cavitate and water flow will be diminished. **Cavitation due to improper strainer maintenance will damage the pump and is not covered under warranty.** Clean the strainer whenever there is a significant accumulation of debris or an indication of biological growth on the strainer.

To Replace or Clean the Strainer

To replace or clean the strainer, **place the main power switch to the OFF position**, unscrew counterclockwise and lift the strainer out of the reservoir. Remove debris from the mesh using a cleaning agent and water. A soft-bristled brush can be used to loosen the debris. Be careful not to tear the nylon mesh. If debris accumulates inside the strainer or if the strainer becomes damaged in some way, replace the strainer. Thread the strainer onto the fittings until hand tight.

5.3.2 Supply Line Filter Option

A supply-line filter (Figure 5-1) is similar to a strainer, but it is located in the supply water line external to the system frame. This filter will help prevent debris from entering the system and can also provide significant protection against algae growth in the tank.



Figure 5-1.
Supply Line Filter

Replacing a Supply-Line Filter

Record the operating water pressure during start-up of your Haskris LX system, when the filter element is clean. The operating water pressure can be read by viewing the water pressure gauge (furnished). Replace the filter when the pressure increases 5-6 psi (0.03 - 0.04 MPa) above the initial start-up pressure. Replacement filter elements may be ordered by contacting Haskris.

5.4 Pump Replacement

To remove the pump from the Haskris LX system, begin by removing all hoses from the pump. Remove only the outside bolts from the pump base (see Figure 5-2).

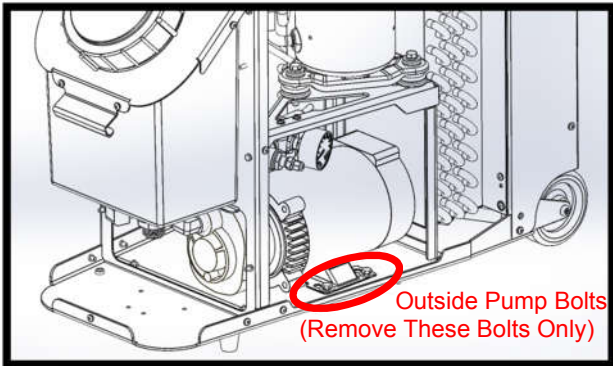

Figure 5-2. Pump Removal

The inner mounting bolts are removed by one of the following ways:

Units with 4 casters:

These bolts are unscrewed from the underside of the chiller. The casters allow 2-3" of clearance to remove the (2) bolts.

Units with 2 casters:

These studs are designed to slide along the base of the unit and do not need be removed (see Figure 5-3).

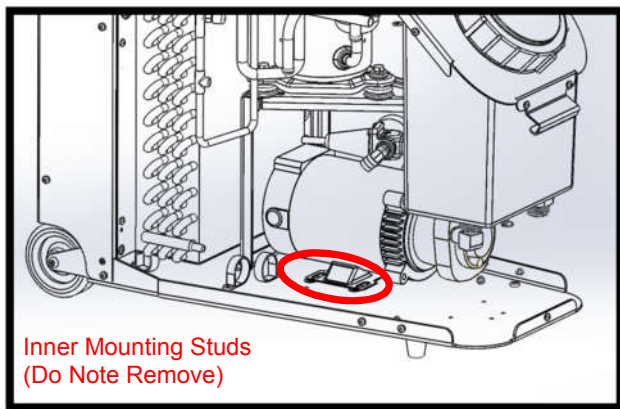

Figure 5-3. Inner Mounting Studs

Once the bolts are removed from the accessible side of the pump, slide the pump towards the center of the unit until it becomes loose. Note that the inner mounting studs will slide with the pump. Lift the pump straight upward until the inner mounting studs have cleared the base of the unit.

Once the pump's inner mounting bolts are disengaged, remove the pump through the side of the unit.

5.5 Drain line

The LX units come with a drain hose for ease of emptying the tank. This is located on the left side of the unit (from the front view) and can be reached by removing the left panel and opening the drain metering device or ball valve.

6 WARRANTY

6.1 Standard Product Warranty

Limited Warranty: Haskris' warranty is limited to the following provisions and does not apply to claims where the product has been mishandled or used in a manner inconsistent with this instruction manual. Haskris makes no other warranty, express or implied, including all implied warranties of merchantability and fitness for a particular purpose.

Term & Conditions Provisions: Warranty extends for one (1) year from date of start-up or shipment (from Haskris), in no event longer than 18-months from the date of shipment. The warranty includes parts and on-site labor. Any warranty labor must be authorized by Haskris, in writing, prior to proceeding with the repairs.

Parts Provisions: Parts warranty does not include consumable items such as filtration elements. Replacement parts furnished during the system warranty are covered until the system warranty expires. Parts purchased after the system warranty expires will be covered for a period of 90-days. Defective parts must be returned, transportation prepaid, to Haskris Company. Normal outgoing surface transportation charges will be paid by Haskris.

